

# SOLENOID OPERATED CARTRIDGE VALVES

插入式電磁閥

## VSV SERIES CARTRIDGE TYPE SOLENOID OPERATED CHECK VALVES

vsv 系列插入式電磁止逆閥

### ◆ MODEL 型 式 VSV8A-25

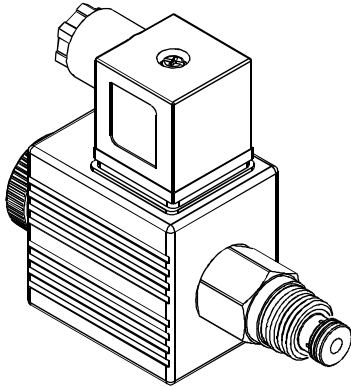

### ◆ PERFORMANCE 特性曲線

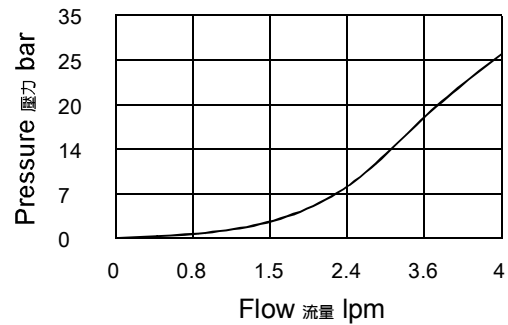

### ◆ SPECIFICATIONS 規 格

Model Number 型式號碼	Maximum Pressure 最大壓力 bar	Maximum Flow 最大流量 lpm	Weight 重量 Kg
VSV8A-25	350 (5076 psi)	1 (0.26 gpm)	0.55 (1.21 lbs)
<b>Fluid Type 流體型式</b>		ISO VG 32, 46, 68	
<b>Viscosity 黏性 cSt</b>		10~400 (59~1854 SSU)	
<b>Operating Temperature 操作溫度 °C</b>		-30~100 (-22~212°F)	
<b>Contamination Level 污染標準</b>		ISO4406. 20/18/15 NAS1638. 9	

● Internal Leakage: max of 0.6 cc/min (10 drops/min) at 210 bar (3046 psi).  
內部洩漏:在210bar(3046psi)時,最大為0.6毫升/分鐘(10滴/分鐘)。

### ◆ HOW TO ORDER 編號說明

<b>1</b>	<b>2</b>	<b>3</b>	<b>4</b>	<b>5</b>	<b>6</b>	<b>7</b>					
VSV	8A	—	25	—	A2	—	X	—	Y	—	*

#### 1 VALVE SERIES 系列名稱

VSV=Cartridge Type Solenoid Operated  
Check Valves 插入式電磁止逆閥

#### 2 SUBPLATE MOUNTING SIZE 稱呼口徑

8A : T-8A  
Cavity 孔口: CST-8A  
See Appendices-A 見附錄A  
For Manifold See Appendices-B 油路板見附錄B

#### 3 CONTROL PORT(S) 動作形式

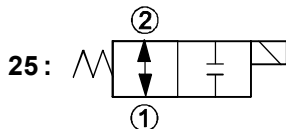

#### 4 TYPE OF COIL 線圈類型

Non : Without Coil 無記號:無線圈  
A1 : RAC110V 60/50HZ D1 : DC12V  
A2 : RAC220V 60/50HZ D2 : DC24V

#### 5 WIRING TYPE 接線型式

Non: WIRING BOX TYPE (DIN) 無:接線盒式 (DIN) X: DOUBLE LEAD 雙接線方式



※ For more technical information of wiring type please refer to the Appendices-D or contact with us .  
接線型式的詳細技術資料請查附錄-D或與我們聯繫。

#### 6 ADJUSTMENT OPTION 調整選擇

<b>Non</b> Non:Standard 無記號:標準型		<b>Y</b> Y:Push Style Manual Override 推壓型-手動操作復位	
---------------------------------------	--	---	--

#### 7 SEALS 密封件

Non : NBR (Standard) 無記號:丁腈橡膠(標準型)  
HN : HNBR HN: 氯化丁腈橡膠  
V : VITON V: 氟橡膠

### ◆ DIMENSIONS 外型尺寸圖

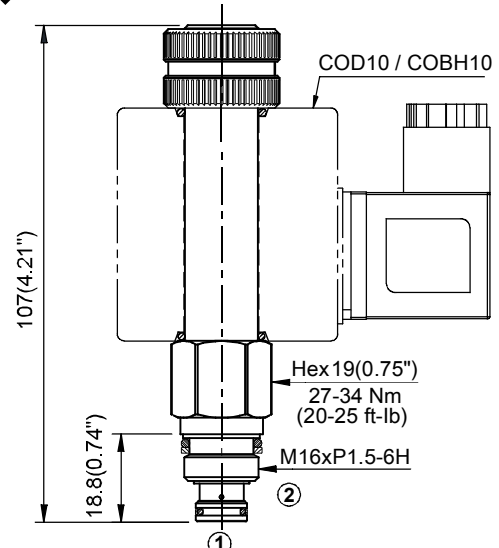

● There are only two specifications in COBH10 coil H(DIN) type and X type. COBH10線圈只有H(DIN)、X兩種規格