

SOLENOID OPERATED CARTRIDGE VALVES

插入式電磁閥

VSV SERIES CARTRIDGE TYPE SOLENOID OPERATED CHECK VALVES

vsv 系列插入式電磁止逆閥

MODEL 型式 VSV8A-24

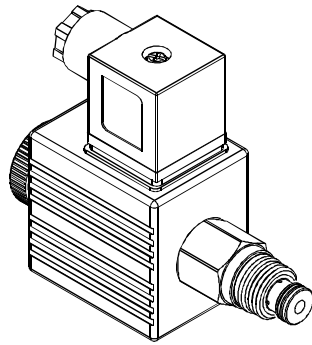

PERFORMANCE 特性曲線

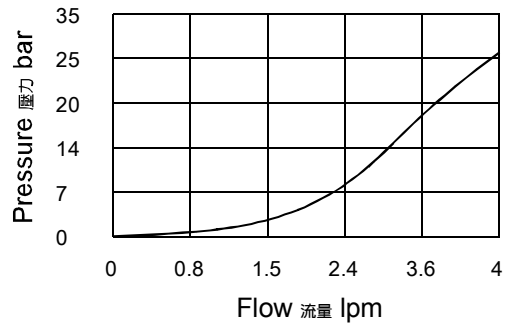

SPECIFICATIONS 規格

Model Number 型式號碼	Maximum Pressure 最大壓力 bar	Maximum Flow 最大流量 lpm	Weight 重量 Kg
VSV8A-24	350 (5076 psi)	1 (0.26 gpm)	0.55 (1.21 lbs)
Fluid Type 流體型式	ISO VG 32, 46, 68		
Viscosity 黏性 cSt	10~400 (59~1854 SSU)		
Operating Temperature 操作溫度 °C	-30~100 (-22~212°F)		
Contamination Level 污染標準	ISO4406. 20/18/15 NAS1638. 9		

● Internal Leakage: max of 0.6 cc/min (10 drops/min) at 210 bar (3046 psi).
內部泄漏: 在210bar(3046psi)時, 最大為0.6毫升/分鐘(10滴/分鐘)。

HOW TO ORDER 編號說明

1	2	3	4	5	6	7
VSV	8A	— 24	— A2	— X	— Y	— *

6 ADJUSTMENT OPTION 調整選擇

Non	M	Y
Non: Standard 無記號: 標準型	M: Push and Twist Style Manual Override (Twist & lock (detent)) 推壓扭轉型 - 手動操作復位 (推壓扭轉定位)	Y: Push Style Manual Override 推壓型 - 手動操作復位

1 VALVE SERIES 系列名稱

VSV=Cartridge Type Solenoid Operated
Check Valves 插入式電磁止逆閥

2 SUBPLATE MOUNTING SIZE 稱呼口徑

8A : T-8A
Cavity 孔口: CST-8A
See Appendices-A 見附錄A
For Manifold See Appendices-B 油路板見附錄B

3 CONTROL PORT(S) 動作形式

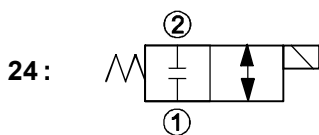

4 TYPE OF COIL 線圈類型

Non: Without Coil 無記號: 無線圈
A1 : RAC110V 60/50HZ D1 : DC12V
A2 : RAC220V 60/50HZ D2 : DC24V

5 WIRING TYPE 接線型式

Non: WIRING BOX TYPE (DIN) X: DOUBLE LEAD
無: 接線盒式 (DIN) 雙接線方式



※ For more technical information of wiring type please refer to the Appendices-D or contact with us.
接線型式的詳細技術資料請查附錄-D或與我們聯繫。

7 SEALS 密封件

Non: NBR (Standard) 無記號: 丁腈橡膠(標準型)
HN: HNBR HN: 氫化丁腈橡膠
V: VITON V: 氟橡膠

DIMENSIONS 外型尺寸圖

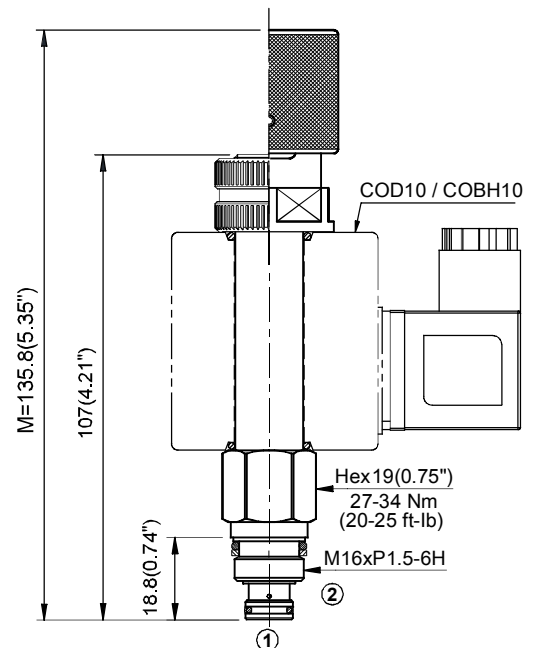

● There are only two specifications in COBH10 coil H(DIN) type and X type. COBH10線圈只有H(DIN)、X兩種規格