

◆ **MODEL 型 式**  
VSV16-22

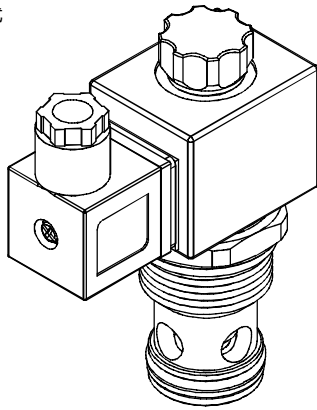

◆ **PERFORMANCE 特性曲線**

**Pressure Drop 壓力降**

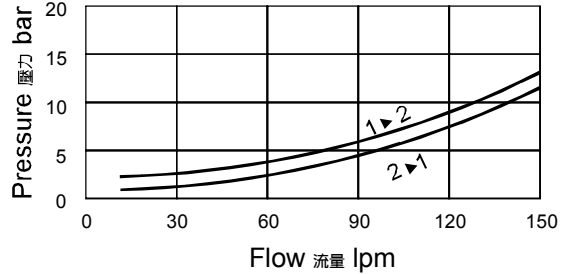

◆ **SPECIFICATIONS 規 格**

Model Number 型式號碼	Maximum Pressure 最大壓力 bar	Maximum Flow 最大流量 lpm	Weight 重量 Kg
VSV16-22	350 (5076 psi)	150 (39.63 gpm)	0.71 (1.57 lbs)
<b>Fluid Type 流體型式</b>	ISO VG 32, 46, 68		
<b>Viscosity 黏性 cSt</b>	10~400 (59~1854 SSU)		
<b>Operating Temperature 操作溫度 °C</b>	-30~100 (-22~212°F)		
<b>Contamination Level 污染標準</b>	ISO4406. 20/18/15 NAS1638. 9		

● Internal Leakage: max of 0.15 cc/min (3 drops/min) at 350 bar (5076 psi).  
內部泄漏:在350bar(5076psi)時,最大為0.15毫升/分鐘(3滴/分鐘)。

◆ **HOW TO ORDER 編號說明**

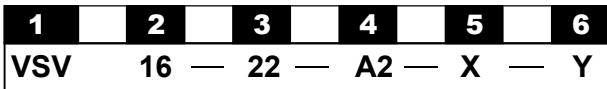

**1 VALVE SERIES 系列名稱**

VSV=Cartridge Type Solenoid Operated Check Valves 插入式電磁止逆閥

**2 SUBPLATE MOUNTING SIZE 稱呼口徑**

Size:16  
Cavity 孔口: CS16-2N  
See Appendices-A 見附錄A  
For Manifold See Appendices-B 油路板見附錄B

**3 CONTROL PORT(S) 動作形式**

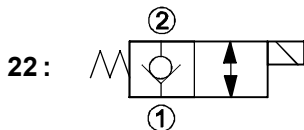

**4 TYPE OF COIL 線圈類型**

Non: Without Coil 無記號:無線圈  
A1 : RAC110V 60/50HZ D1 : DC12V  
A2 : RAC220V 60/50HZ D2 : DC24V

**5 WIRING TYPE 接線型式**

Non:WIRING BOX TYPE (DIN) X: DOUBLE LEAD  
無:接線盒式 (DIN) 雙接線方式



※ For more technical information of wiring type please refer to the Appendices-D or contact with us.  
接線型式的詳細技術資料請查附錄-D或與我們聯繫。

**6 ADJUSTMENT OPTION 調整選擇**

<b>Non</b> Non:Standard 無記號:標準型	
<b>Y</b> Y:Twist Style Manual Override 旋緊型-手動操作復位	

◆ **DIMENSIONS 外型尺寸圖**

