

# SOLENOID OPERATED CARTRIDGE VALVES

插入式電磁閥

## VSV SERIES CARTRIDGE TYPE SOLENOID OPERATED CHECK VALVES

vsv 系列插入式電磁止逆閥

### ◆ MODEL 型 式

VSV084-22

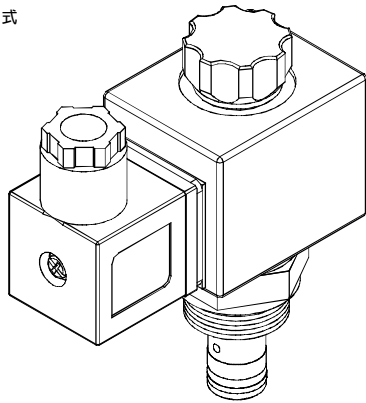

### ◆ PERFORMANCE 特性曲線

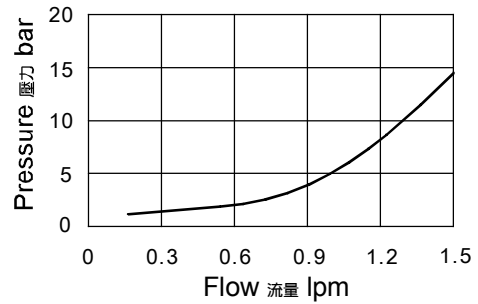

### ◆ SPECIFICATIONS 規 格

Model Number 型式號碼	Maximum Pressure 最大壓力 bar	Maximum Flow 最大流量 lpm	Weight 重量 Kg
VSV084-22	350 (5076 psi)	1.5 (0.40 gpm)	0.45 (0.99 lbs)
<b>Fluid Type 流體型式</b>		ISO VG 32, 46, 68	
<b>Viscosity 黏性 cSt</b>		10~400 (59~1854 SSU)	
<b>Operating Temperature 操作溫度 °C</b>		-30~100 (-22~212°F)	
<b>Contamination Level 污染標準</b>		ISO4406. 20/18/15 NAS1638.9	

● Internal Leakage: max of 0.15 cc/min (3 drops/min) at 350 bar (5076 psi).  
 內部洩漏: 在350bar(5076psi)時, 最大為0.15毫升/分鐘(3滴/分鐘)。

### ◆ HOW TO ORDER 編號說明

<b>1</b>	<b>2</b>	<b>3</b>	<b>4</b>	<b>5</b>	<b>6</b>
VSV	084	— 22 —	A2	— X —	Y

#### 1 VALVE SERIES 系列名稱

VSV=Cartridge Type Solenoid Operated  
 Check Valves 插入式電磁止逆閥

#### 2 SUBPLATE MOUNTING SIZE 稱呼口徑

Size:08  
 Cavity 孔口: CS08-2N  
 See Appendices-A 見附錄A  
 For Manifold See Appendices-B 油路板見附錄B

#### 3 CONTROL PORT(S) 動作形式

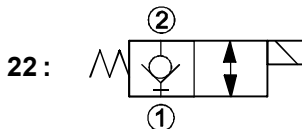

#### 4 TYPE OF COIL 線圈類型

Non: Without Coil 無記號:無線圈  
 A1 : RAC110V 60/50HZ      D1 : DC12V  
 A2 : RAC220V 60/50HZ      D2 : DC24V

#### 5 WIRING TYPE 接線型式

Non: WIRING BOX TYPE (DIN)      X: DOUBLE LEAD  
 無: 接線盒式 (DIN)                  雙接線方式



※ For more technical information of wiring type please refer to the Appendices-D or contact with us.  
 接線型式的詳細技術資料請查附錄-D或與我們聯繫。

#### 6 ADJUSTMENT OPTION 調整選擇

<b>Non</b> Non: Standard 無記號: 標準型	
<b>Y</b> Y: Twist Style Manual Override 旋緊型 - 手動操作復位	

### ◆ DIMENSIONS 外型尺寸圖

