

◆ **MODEL 型 式**
VSV08-29

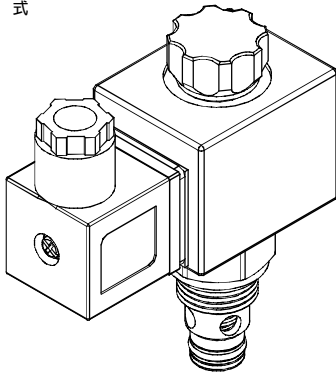

◆ **PERFORMANCE 特性曲線**

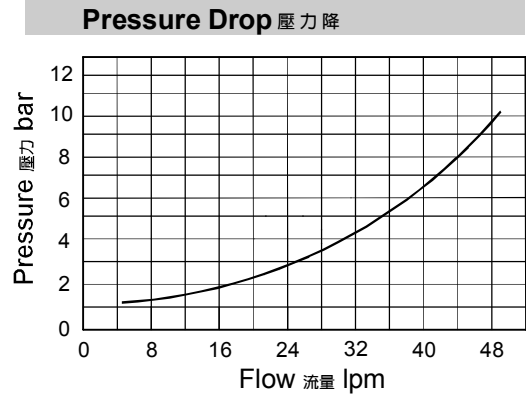

◆ **SPECIFICATIONS 規 格**

Model Number 型式號碼	Maximum Pressure 最大壓力 bar	Maximum Flow 最大流量 lpm	Weight 重量 Kg
VSV08-29	350 (5076 psi)	40 (10.57 gpm)	0.45 (0.99 lbs)
Fluid Type 流體型式		ISO VG 32, 46, 68	
Viscosity 黏性 cSt		10~400 (59~1854 SSU)	
Operating Temperature 操作溫度 °C		-30~100 (-22~212°F)	
Contamination Level 污染標準		ISO4406. 20/18/15 NAS1638. 9	

● Internal Leakage: max of 0.15 cc/min (3 drops/min) at 350 bar (5076 psi).
內部洩漏:在350bar(5076psi)時,最大為0.15毫升/分鐘(3滴/分鐘)。

◆ **HOW TO ORDER 編號說明**

1	2	3	4	5	6
VSV	08	— 29 —	A2	X	Y

1 VALVE SERIES 系列名稱

VSV=Cartridge Type Solenoid Operated Check Valves 插入式電磁止逆閥

2 SUBPLATE MOUNTING SIZE 稱呼口徑

Size : 08
Cavity 孔口 : CS08-2N
See Appendices-A 見附錄A
For Manifold See Appendices-B 油路板見附錄B

3 CONTROL PORT(S) 動作形式

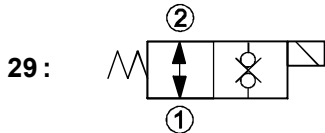

4 TYPE OF COIL 線圈類型

Non: Without Coil 無記號:無線圈
A1 : RAC110V 60/50HZ D1 : DC12V
A2 : RAC220V 60/50HZ D2 : DC24V

5 WIRING TYPE 接線型式

Non:WIRING BOX TYPE(DIN) X: DOUBLE LEAD
無:接線盒式(DIN) 雙接線方式



※ For more technical information of wiring type please refer to the Appendices-D or contact with us.
接線型式的詳細技術資料請查附錄-D或與我們聯繫。

6 ADJUSTMENT OPTION 調整選擇

Non Non:Standard 無記號:標準型		S S:Twist Style Manual Override 旋緊型-手動操作復位	
M M:Push and Twist Style Manual Override 推壓扭轉型-手動操作復位		Y Y:Push Style Manual Override 推壓型-手動操作復位	

◆ **DIMENSIONS 外型尺寸圖**

