

◆ **MODEL 型 式**
VSV08-20

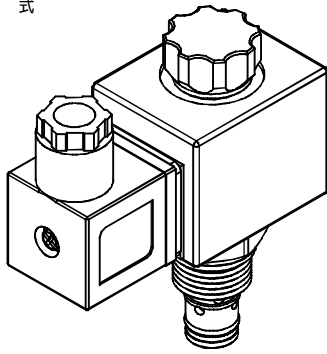

◆ **PERFORMANCE 特性曲線**

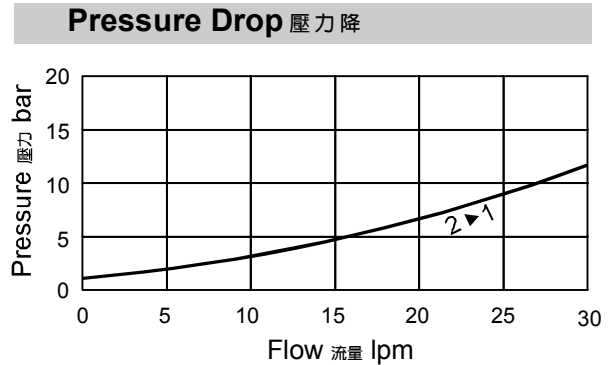

◆ **SPECIFICATIONS 規 格**

Model Number 型式號碼	Maximum Resist Pressure 最大耐壓 bar	Maximum Operating Pressure 最大工作壓力 bar	Maximum Flow 最大流量 lpm	Rated Flow 額定流量 lpm	Weight 重量 Kg
VSV08-20MF	350 (5076 psi)	250 (3626 psi)	35 (9.25 gpm)	30 (7.93 gpm)	0.45 (0.99 lbs)
VSV08-20	350 (5076 psi)	350 (5076 psi)			
Fluid Type 流體型式			ISO VG 32, 46, 68		
Viscosity 黏性 cSt			10~400 (59~1854 SSU)		
Operating Temperature 操作溫度 °C			-30~100 (-22~212°F)		
Contamination Level 污染標準			ISO4406. 20/18/15 NAS1638. 9		

◆ **HOW TO ORDER 編號說明**

1	2	3	4	5	6
VSV	08	— 20 —	A2	X	Y

● Internal Leakage: max of 0.15 cc/min (3 drops/min) at 350 bar (5076 psi).
內部洩漏:在350bar(5076psi)時,最大為0.15毫升/分鐘(3滴/分鐘)。

1 VALVE SERIES 系列名稱

VSV=Cartridge Type Solenoid Operated
Check Valves 插入式電磁止逆閥

2 SUBPLATE MOUNTING SIZE 稱呼口徑

Size:08
Cavity 孔口: CS08-2N
See Appendices-A 見附錄A
For Manifold See Appendices-B 油路板見附錄B

3 CONTROL PORT(S) 動作形式



4 TYPE OF COIL 線圈類型

Non: Without Coil 無記號:無線圈
A1 : RAC110V 60/50HZ D1 : DC12V
A2 : RAC220V 60/50HZ D2 : DC24V

5 WIRING TYPE 接線型式

Non: WIRING BOX TYPE (DIN) 無接線盒式 (DIN) X: DOUBLE LEAD 雙接線方式



※ For more technical information of wiring type please refer to the Appendices-D or contact with us.
接線型式的詳細技術資料請查附錄-D或與我們聯繫。

6 ADJUSTMENT OPTION 調整選擇

Non Non: Standard 無記號:標準型		Z Z: Cable Operated Pull Style Override 軟軸控制型- 拉動式操作復位	 M8xP1.25
Y Y: Twist Style Manual Override 旋緊型- 手動操作復位		P P: Hand Operated Pull Style Override 手控型- 拉動式操作復位	

◆ **DIMENSIONS 外型尺寸圖**

