

◆ **MODEL 型 式**  
VSE12-30

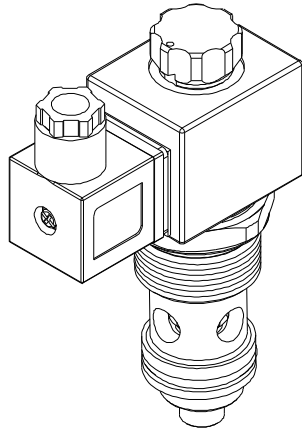

◆ **PERFORMANCE 特性曲線**

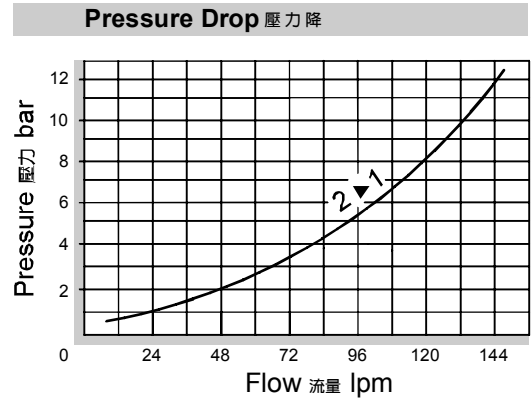

◆ **SPECIFICATIONS 規 格**

Model Number 型式號碼	Maximum Pressure 最大壓力 bar	Maximum Flow 最大流量 lpm	Weight 重量 Kg
VSE12-30	350 (5076 psi)	150 (39.63 gpm)	0.66 (1.46 lbs)
<b>Fluid Type 流體型式</b>		ISO VG 32, 46, 68	
<b>Viscosity 黏性 cSt</b>		10~400 (59~1854 SSU)	
<b>Operating Temperature 操作溫度 °C</b>		-30~100 (-22~212°F)	
<b>Contamination Level 污染標準</b>		ISO4406. 20/18/15 NAS1638. 9	

◆ **HOW TO ORDER 編號說明**

<b>1</b>	<b>2</b>	<b>3</b>	<b>4</b>	<b>5</b>	<b>6</b>
VSE	12	—	30	—	A2 — X — Y

**1 VALVE SERIES 系列名稱**  
VSE=Cartridge Type Solenoid Operated  
Check Valves 插入式電磁止逆閥

**2 SUBPLATE MOUNTING SIZE 稱呼口徑**  
12 : E-021  
Cavity 孔口: CSE 021-2N  
See Appendices-A 見附錄A  
For Manifold See Appendices-B 油路板見附錄B

**3 CONTROL PORT(S) 動作形式**

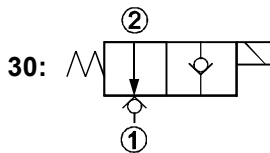

**4 TYPE OF COIL 線圈類型**  
Non : Without Coil 無記號:無線圈  
A1 : RAC110V 60/50HZ      D1 : DC12V  
A2 : RAC220V 60/50HZ      D2 : DC24V

**5 WIRING TYPE 接線型式**  
Non:WIRING BOX TYPE(DIN)      X : DOUBLE LEAD  
無:接線盒式 (DIN)                  雙接線方式



※ For more technical information of wiring type please refer to the Appendices-D or contact with us .  
接線型式的詳細技術資料請查附錄-D或與我們聯繫。

**6 ADJUSTMENT OPTION 調整選擇**

<b>Non</b> Non:Standard 無記號:標準型	
<b>Y</b> Y:Push Style Manual Override 推壓型— 手動操作復位	

◆ **DIMENSIONS 外型尺寸圖**

