

◆ MODEL 型式

VPN-08

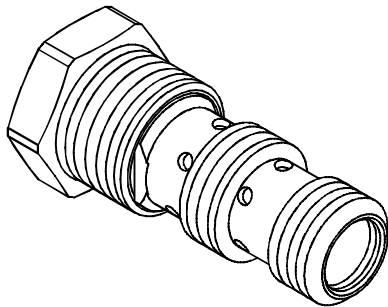

◆ PERFORMANCE 特性曲線 (Cartridge Only)

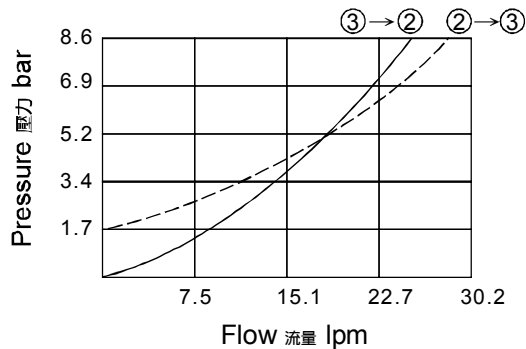

◆ SPECIFICATIONS 規格

Model Number 型式號碼	Maximum Pressure 最大壓力 bar	Operating Pressure 操作壓力 bar	Pilot Ratio 引導比例	Flow 流量 lpm	Weight 重量 Kg
VPN-08	350 (5076psi)	250 (3626 psi)	3:1 / 4:1	23 (6.08 gpm)	0.1 (0.22 lbs)
Fluid Type 流體型式			ISO VG 32, 46, 68		
Viscosity 黏性 cSt			10~400 (59~1854 SSU)		
Operating Temperature 操作溫度 °C			-30~100 (-22~212°F)		
Contamination Level 污染標準			ISO4406. 20/18/15 NAS1638. 9		

◆ HOW TO ORDER 編號說明

1	2	3	4	5
VPN	08	— 3A	— *	— *

1 VALVE SERIES 系列名稱

VPN = Cartridge Pilot Operated Check Valves
插入式引導止逆閥

2 PORTING 閥口

Size:08
Cavity 孔口:CS08-3N
See Appendices-A 見附錄A
For Manifold See Appendices-B 油路板見附錄B

3 PILOT RATIO 引導比例

3A : 3:1
4A : 4:1

4 CRACKING PRESSURE 開啓壓力

05 : 0.5 bar (7psi)
20 : 2 bar (29psi)
50 : 5 bar (72psi)

- The seal kit of the pilot piston has a minimum spring pressure of 2 bar.

導壓活塞帶密封件最低彈簧壓力為2bar.

5 SEALS 密封件

Non : NBR (Standard) 無記號 : 丁腈橡膠(標準型)
HN : HNBR HN: 氫化丁腈橡膠
V : VITON V: 氟橡膠

◆ CONTROL PORT(S) 動作形式

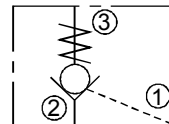

◆ DIMENSIONS 外型尺寸圖

