

◆ **MODEL 型 式**

**VPK-08**

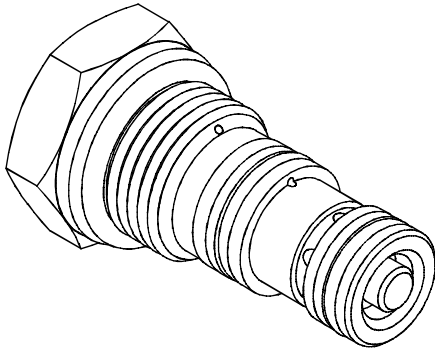

◆ **PERFORMANCE(Cartridge Only)**

特性曲線

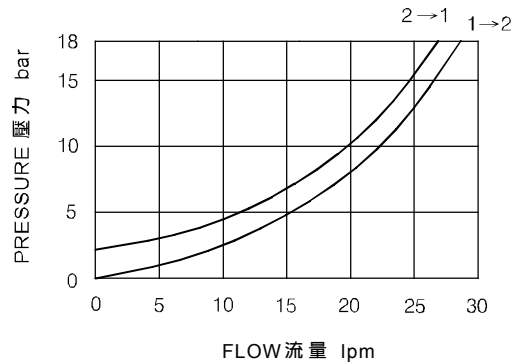

◆ **SPECIFICATIONS 規 格**

Model Number 型式號碼	Maximum Pressure 最大壓力 bar	Cracking Pressure 開啟壓力 bar	Maximum Flow 最大流量 Lpm	Weight 重量 Kg
VPK-08	350 ( 5076 psi)	2 ( 29 psi)	30 (7.93 gpm)	0.12 ( 0.27 lbs)
<b>Fluid Type</b> 流體型式		ISO VG 32,46,68		
<b>Viscosity</b> 黏性 cSt		10~400 (59~1854SSU)		
<b>Operating Temperature</b> 操作溫度 °C		-15~70 (-5~158°F)		
<b>Contamination Level</b> 污染標準		ISO4406. 21/19/16 NAS1638,10		

◆ **HOW TO ORDER 編號說明**

<b>1</b>	<b>2</b>	<b>3</b>
VPK	08	*

**1 VALVE SERIES 系列名稱**

VPK=CARTRIDGE PILOT  
OPERATED CHECK VALVES

插入式引導止逆閥

**2 SUBPLATE MOUNTING SIZE 稱呼口徑**

Size : 08  
Cavity 孔口:CS08-3S  
See Page Appendixes-A\_003  
見附錄A\_003 頁面

**3 PILOT RATIO 引導比例**

3A : 3:1  
4A : 4:1

◆ **CONTROL PORT(S) 動作形式**

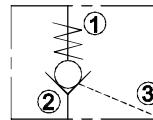

◆ **DIMENSIONS 外型尺寸圖**

