

◆ MODEL 型式 VLSL-03

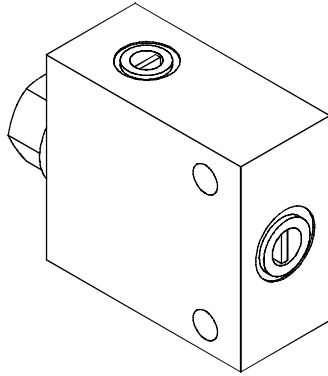

◆ DESCRIPTION 說明

Shuttle Valves, cartridge-style hydraulic check valve, for use in blocking circuits where a priority of flow/direction is given to a higher pressure circuit over a lower one.

梭動閥，插入式油壓止逆閥，在流量/方向被優先供應至較高的壓力迴路時，用於阻擋低壓迴路。

◆ PERFORMANCE 特性曲線 (Cartridge Only)

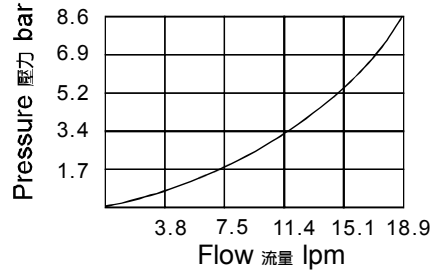

◆ SPECIFICATIONS 規格

Model Number 型式號碼	Maximum Pressure 最大壓力 bar	Flow 流量 lpm	Weight 重量 Kg
VLSL-03	350 (5076psi)	19 (5.02 gpm)	1.07 (2.36 lbs)
Fluid Type 流體型式		ISO VG 32, 46, 68	
Viscosity 黏性 cSt		10~400 (59~1854 SSU)	
Operating Temperature 操作溫度 °C		-30~100 (-22~212°F)	
Contamination Level 污染標準		ISO4406. 20/18/15 NAS1638. 9	

◆ HOW TO ORDER 編號說明

1	2	3	4
VLSL	03	— *	— *



Body Material 閥體材質	Maximum Pressure 最大壓力 bar	Weight 重量 Kg
Aluminum (standard) 鋁 (標準)	260 (3771 psi)	0.42 (0.93 lbs)
Nodular Ductile-Iron 球墨鑄鐵	350 (5076 psi)	1.07 (2.36 lbs)

1 VALVE SERIES 系列名稱

VLSL= Shuttle Valves 梭動閥

2 PORTING 閥口

03=3/8

3 THREADED TYPE 螺紋規格

1P : PT 3G : PF(G)
2N : NPT 4A : SAE 5B : BSP

4 BODY MATERIAL 閥體材質

NONE (Standard): Aluminum-alloy 無 (標準): 鋁合金
D : Nodular Ductile-Iron 球墨鑄鐵

◆ CONTROL PORT(S) 動作形式

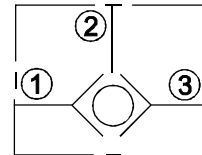

◆ DIMENSIONS 外型尺寸圖

外型尺寸圖

