

◆ MODEL 型 式

VCX-02

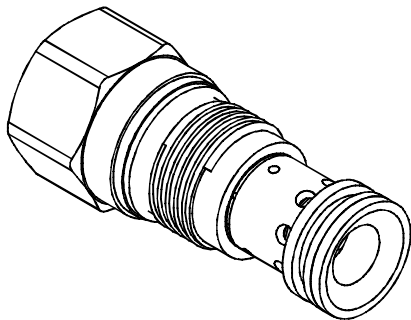

◆ PERFORMANCE (Cartridge Only)

特性曲線

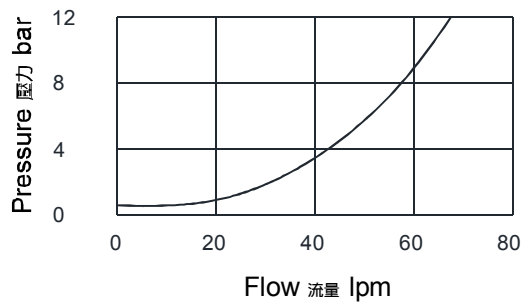

◆ SPECIFICATIONS 規 格

Model Number 型式號碼	Operating Pressure 操作壓力 bar	Flow 流量 lpm	Weight 重量 Kg
VCX-02	350 (5076 psi)	80 (21.13 gpm)	0.15 (0.33 lbs)
Fluid Type 流體型式		ISO VG 32, 46, 68	
Viscosity 黏性 cSt		10~400 (59~1854 SSU)	
Operating Temperature 操作溫度 °C		-30~100 (-22~212°F)	
Contamination Level 污染標準		ISO4406. 20/18/15 NAS1638. 9	

◆ HOW TO ORDER 編號說明

1	2	3
VCX	02	05

1 VALVE SERIES 系列名稱

VCX = Check Valves 止逆閥

2 PORTING 閥口

02 : T-13A
Cavity 孔口 : CST-13A
See Appendices-A 見附錄A
For Manifold See Appendices-B 油路板見附錄B

3 CRACKING PRESSURE 開啓壓力

05 : 0.35 bar (5 psi)
20 : 2 bar (29 psi)
50 : 5 bar (73 psi)
70 : 7 bar (101.5 psi)
100 : 10.5 bar (150 psi)

◆ CONTROL PORT(S) 動作形式

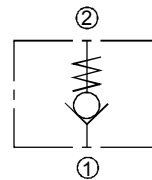

◆ DIMENSIONS 外型尺寸圖

