

◆ MODEL 型式

VCK-10

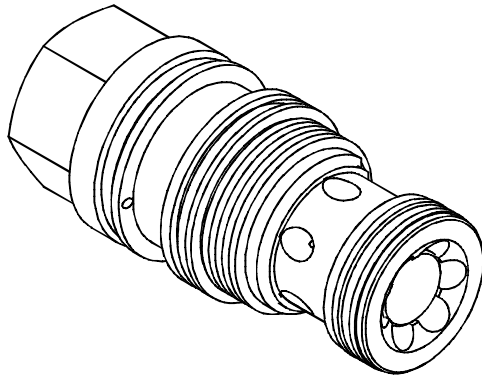

◆ PERFORMANCE (Cartridge Only)

特性曲線

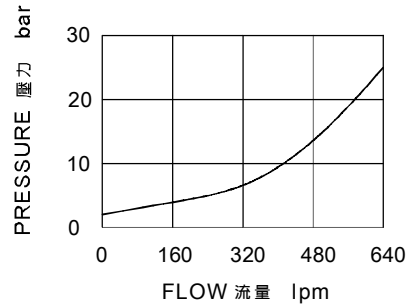

◆ SPECIFICATIONS 規格

Model Number 型式號碼	Operating Pressure 操作壓力 bar	Pilot Ratio 引導比例	Flow 流量 lpm	Weight 重量 Kg
VCK-10	350 (5076 psi)	3:1	460 (121.52 gpm)	1.3 (2.87 lbs)
Fluid Type 流體型式		ISO VG 32, 46, 68		
Viscosity 黏性 cSt		10~400 (59~1854 SSU)		
Operating Temperature 操作溫度 °C		-30~100 (-22~212°F)		
Contamination Level 污染標準		ISO4406. 21/19/16 NAS1638,10		

◆ HOW TO ORDER 編號說明

1	2	3
VCK	10	— 20

1 VALVE SERIES 系列名稱

VCK= CARTRIDGE PILOT OPERATED CHECK VALVES
插入式引導止逆閥

2 PORTING 閥口

10 : T-19A

Cavity 孔口 : CST-19A

See Page Appendixes-A_007
見附錄A_007 頁面

3 BIAS SPRING 開啓壓力

03 : 0.3 bar (4psi)

20 : 2 bar (29psi)

50 : 5 bar (73psi)

◆ CONTROL PORT(S) 動作形式

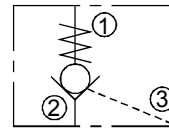

◆ DIMENSIONS 外型尺寸圖

