

◆ **MODEL** 型 式

VCK-06

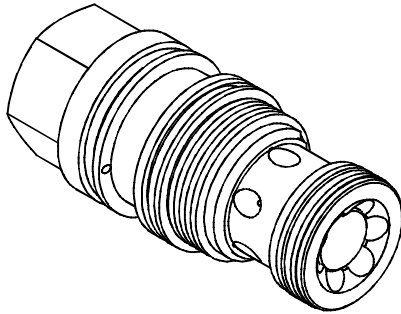

◆ **PERFORMANCE**(Cartridge Only)

特性曲線

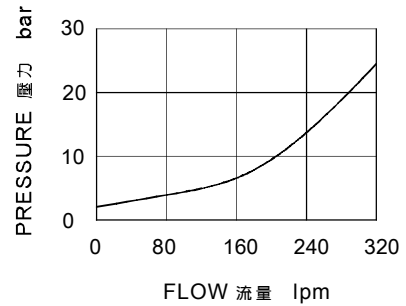

◆ **SPECIFICATIONS** 規 格

Model Number 型式號碼	Operating Pressure 操作壓力 bar	Pilot Ratio 引導比例	Flow 流量 lpm	Weight 重量 Kg
VCK-06	350 (5076 psi)	3:1	200 (52.83 gpm)	0.53 (1.18 lbs)
Fluid Type 流體型式		ISO VG 32, 46, 68		
Viscosity 黏性 cSt		10~400 (59~1854 SSU)		
Operating Temperature 操作溫度 °C		-30~100 (-22~212°F)		
Contamination Level 污染標準		ISO4406. 21/19/16 NAS1638,10		

◆ **HOW TO ORDER** 編號說明

1	2	3
VCK	06	— 20

1 VALVE SERIES 系列名稱

VCK= CARTRIDGE PILOT OPERATED CHECK VALVES
插入式引導止逆閥

2 PORTING 閥口

06 : T-17A
Cavity 孔口 : CST-17A
See Page Appendixes-A_007
見附錄A_007 頁面

3 BIAS SPRING 開啓壓力

03 : 0.3 bar (4psi)
20 : 2 bar (29psi)

◆ **CONTROL PORT(S)** 動作形式

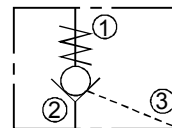

◆ **DIMENSIONS** 外型尺寸圖

