

◆ **MODEL 型式**

VNC-03

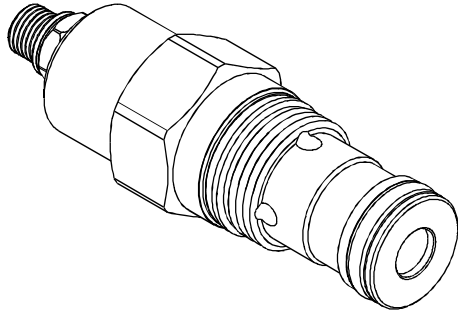

◆ **PERFORMANCE(Cartridge Only)**

特性曲線

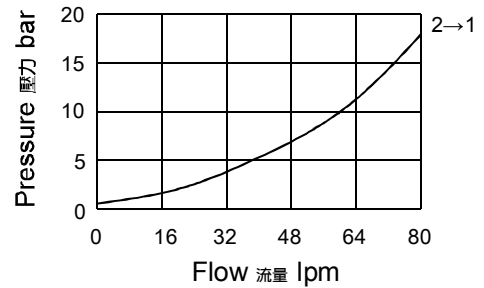

◆ **SPECIFICATIONS 規格**

Model Number 型式號碼	Maximum Pressure 最大壓力 bar	Maximum Flow 最大流量 Lpm	Weight 重量 Kg
VNC-03	350 (5076 psi)	45 (11.89 gpm)	0.28 (0.62 lbs)
Fluid Type 流體型式		ISO VG 32,46,68	
Viscosity 黏性 cSt		10~400 (59~1854SSU)	
Operating Temperature 操作溫度 °C		-30~100 (-22~212°F)	
Contamination Level 污染標準		ISO4406. 20/18/15 NAS1638. 9	

◆ **HOW TO ORDER 編號說明**

1	2	3	4	5
VNC	03	A	20	*

1 VALVE SERIES 系列名稱

VNC= Cartridge Check Throttle Valves
插入式止逆節流閥

2 SUBPLATE MOUNTING SIZE 稱呼口徑

03 : T-5A
Cavity 孔口: CST-5A
See Appendices-A 見附錄A
For Manifold See Appendices-B 油路板見附錄B

3 CONTROL FLOW 控制流量

A : 45 Lpm (11.89 gpm)
B : 11 Lpm (2.91 gpm)

4 CRACKING PRESSURE 開啓壓力

20 : 2 bar (29psi)
50 : 5 bar (73psi)

5 ADJUSTMENT OPTION 調整選擇

NONE	NONE: TOOL ADJUST 無：工具調整式	
K	K: HAND-BAR ADJUST K：手把調整式	
KT	KT: HAND-BAR ADJUST (Three-winged) KT：手把調整式(三翼)	

◆ **CONTROL PORT(S)** 動作形式

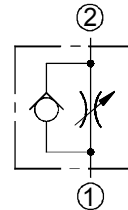

◆ **DIMENSIONS** 外型尺寸圖

