

◆ **MODEL 型 式**  
VFD-05

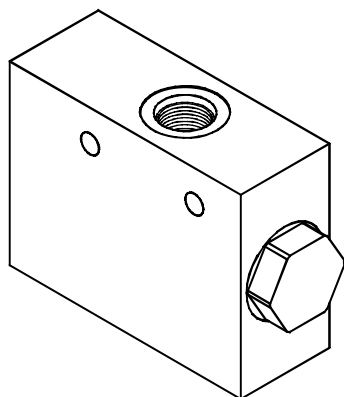

◆ **PERFORMANCE 特性曲線**

Test Conditions 測試條件  
Oil Temperature 油溫度: 50°C (122°F)  
Viscosity 黏性: 35 cSt (163 SSU)

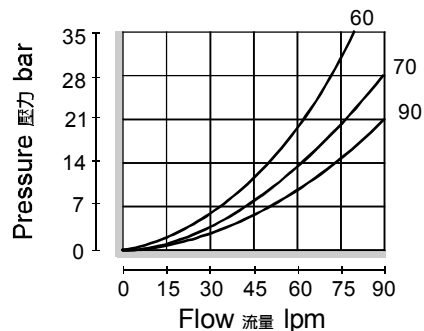

◆ **SPECIFICATIONS 規 格**

Model Number 型式號碼	Operating Pressure 操作壓力 bar	Flow 流量 lpm	Weight 重量 Kg
VFD-05	250 (3626 psi)	90 (23.78 gpm)	2.05 (4.52 lbs)
<b>Fluid Type 流體型式</b>		ISO VG 32, 46, 68	
<b>Viscosity 黏性 cSt</b>		10~400 (59~1854 SSU)	
<b>Operating Temperature 操作溫度 °C</b>		-30~100 (-22~212°F)	
<b>Contamination Level 污染標準</b>		ISO4406. 20/18/15 NAS1638. 9	

◆ **HOW TO ORDER 編號說明**

1	2	3	4
VFD	05A	90	*

**1 VALVE SERIES 系列名稱**

VFD = Flow Divider Valves 分流閥

**2 SUBPLATE MOUNTING SIZE 稱呼口徑**

- 05A: 3/4"
- 05B: 1"
- 05C: 1/2"
- 05D: 1/2", 3/4"

**3 FLOW SPECIFICATIONS 流量規格**

60: 30~60 l/min Division ratio: 50% - 50%  
70: 43~74 l/min 分流比例  
90: 53~90 l/min Flow Accuracy: 3% ~ 10%  
分流精度

◆ **CONTROL PORT(S) 動作形式**

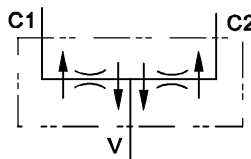

**4 THREADED TYPE 螺紋規格**

1P: PT 2N: NPT 3G: PF(G) 4A: SAE 5B: BSP

◆ **DIMENSIONS 外型尺寸圖**

外型尺寸圖

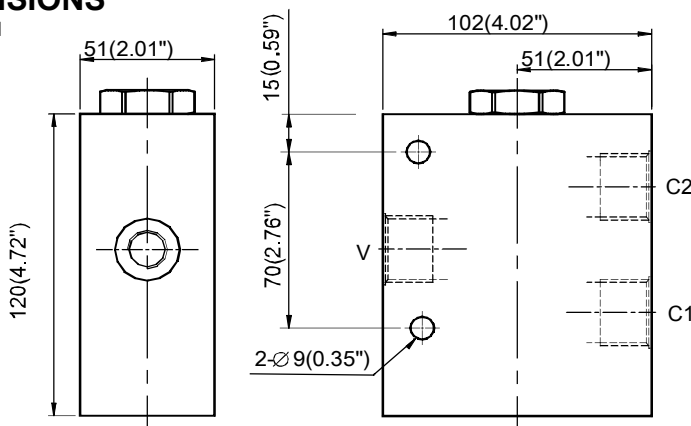

**SUBPLATE MOUNTING SIZE**

※

Mounting Size 口徑	C1	C2	V
05A	3/4"	3/4"	3/4"
05B	1"	1"	1"
05C	1/2"	1/2"	1/2"
05D	1/2"	1/2"	3/4"