

◆ **MODEL 型式**

VCT-10

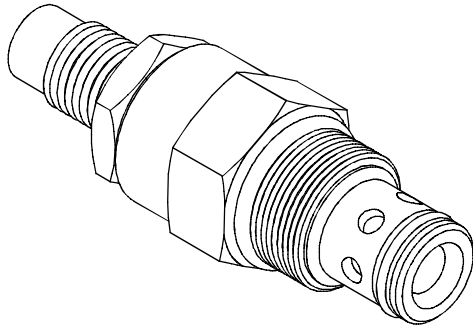

◆ **DESCRIPTION 說明**

A screw-in, cartridge-style, variable orifice, hydraulic flow restrictor valve.

以螺旋調節，插入型式，變動孔口，液壓流量控制閥

◆ **PERFORMANCE**

特性曲線

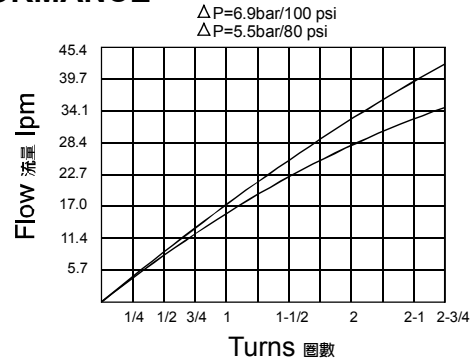

◆ **SPECIFICATIONS 規格**

| Model Number 型式號碼 | Maximum Pressure 最大壓力 bar | Maximum Flow 最大流量 lpm | Weight 重量 Kg |
|-------------------------------|---------------------------|------------------------------|-----------------|
| VCT-10 | 350 (5076 psi) | 75 (19.81 gpm) | 0.18 (0.39 lbs) |
| Fluid Type 流體型式 | | ISO VG 32, 46, 68 | |
| Viscosity 黏性 cSt | | 10~400 (59~1854 SSU) | |
| Operating Temperature 操作溫度 °C | | -30~100 (-22~212°F) | |
| Contamination Level 污染標準 | | ISO4406. 20/18/15 NAS1638. 9 | |

◆ **HOW TO ORDER 編號說明**

| 1 | 2 | 3 | 4 |
|-----|----|-----|-----|
| VCT | 10 | — * | — * |

1 VALVE SERIES 系列名稱

VCT= Cartridge Check Throttle Valves
插入式止逆節流閥

2 SUBPLATE MOUNTING SIZE 稱呼口徑

Size: 10
Cavity 孔口: CS10-2N
See Appendices-A 見附錄A
For Manifold See Appendices-B 油路板見附錄B

3 ADJUSTMENT OPTION 調整選擇

| | | |
|------|-------------------------------|--|
| NONE | NONE: TOOL ADJUST 無：工具調整式 | |
| K | K: HAND-BAR ADJUST K：手把調整式 | |

4 CRACKING PRESSURE 開啓壓力

05 : 0.3bar (4psi)
20 : 2 bar (29psi)
50 : 4 bar (58psi)
200 : 20.4 bar (300psi)

◆ **CONTROL PORT(S) 動作形式**

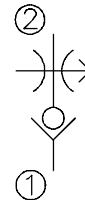

◆ **DIMENSIONS 外型尺寸圖**

