

# PRESSURE CONTROL VALVES 壓力控制閥

VRB SERIES CARTRIDGE BALANCE VALVES (PILOT OPERATED REDUCING/RELIEVING VALVES) VRB 系列插入式平衡閥(導壓操作減泄壓閥)

## ◆ MODEL 型式 VRB-02

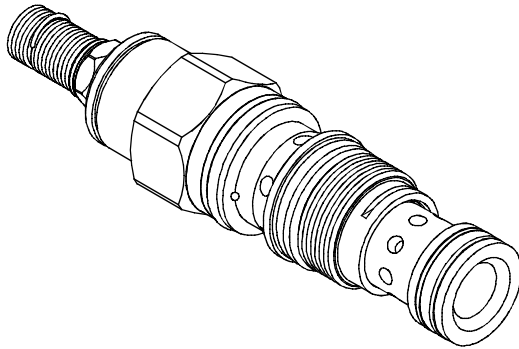

## ◆ PERFORMANCE 特性曲線

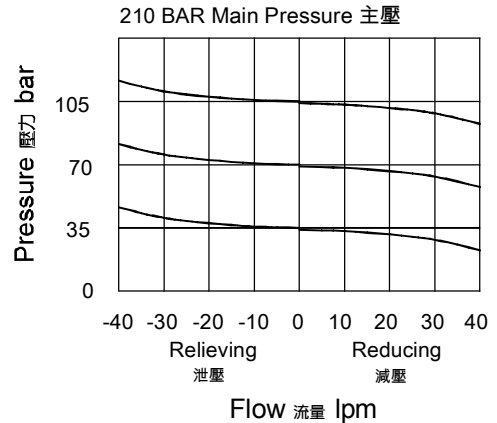

## ◆ SPECIFICATIONS 規格

Model Number 型式號碼	Maximum Pressure 最大壓力 bar	Maximum Flow 最大流量 lpm	Weight 重量 Kg
VRB-02	350 (5076psi)	40 (10.57gpm)	0.18 (0.4 lbs)
Fluid Type 流體型式		ISO VG 32, 46, 68	
Viscosity 黏性 cSt		10~400 (59~1854 SSU)	
Operating Temperature 操作溫度 °C		-30~100 (-22~212°F)	
Contamination Level 污染標準		ISO4406. 20/18/15 NAS1638. 9	

## ◆ HOW TO ORDER 編號說明

1	2	3	4	5
VRB	02	*	*	*

### 1 VALVE SERIES 系列名稱

VRB= Cartridge Balance Valves

(Pilot Operated Reducing/Relieving Valves)

插入式平衡閥(導壓操作減泄壓閥)

### 2 SUBPLATE MOUNTING SIZE 稱呼口徑

02 :T-11A

Cavity 孔口:CST-11A

See Appendices-A 見附錄A

For Manifold See Appendices-B 油路板見附錄B

### 3 ADJUSTMENT PRESSURE 壓力調整範圍

Code 編碼	Adjustment pressure 壓力調整範圍
01	1.7 ~ 28 (bar)
02	4 ~ 28 (bar)
06	4 ~ 60 (bar)
10	4 ~ 105 (bar)
20	7 ~ 210 (bar)
30	10 ~ 315 (bar)
40	12 ~ 420 (bar)

### 4 ADJUSTMENT OPTION 調整選擇

NONE	NONE:TOOL ADJUST 無：工具調整式	
K	K:HAND-BAR ADJUST K：手把調整式	

### 5 DESIGN NO 設計編號

## ◆ CONTROL PORT(S) 動作形式

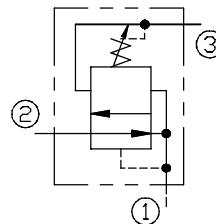

## ◆ DIMENSIONS 外型尺寸圖

