

◆ **MODEL** 型式  
**PCK**

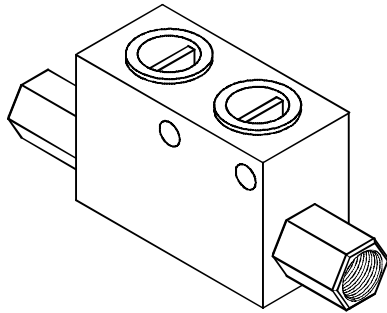

◆ **CONTROL PORT(S)** 動作形式

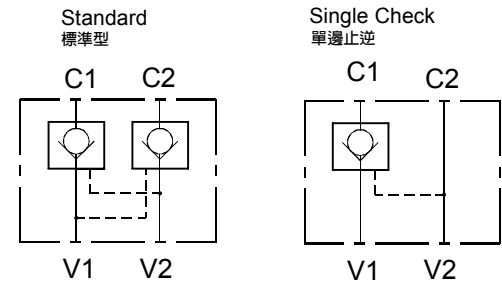

◆ **SPECIFICATIONS** 規格

Model Number 型式號碼	Operating Pressure 操作壓力 bar	Cracking Pressure 操作壓力 bar	Pilot Ratio 引導比例	Flow 流量 lpm	Weight 重量 Kg
PCK-02	320 (4641 psi)	0.5 (7 psi)	4 : 1 / 6 : 1	15 (3.96 gpm)	0.65 (1.43 lbs)
PCK-03				35 (9.25 gpm)	0.65 (1.43 lbs)
PCK-04				50 (13.21 gpm)	1.40 (3.09 lbs)
<b>Fluid Type</b> 流體型式			ISO VG 32 , 46 , 68		
<b>Viscosity</b> 黏性 cSt			10~400 (59~1854 SSU)		
<b>Operating Temperature</b> 操作溫度 °C			-30~100 (-22~212°F)		
<b>Contamination Level</b> 污染標準			ISO4406. 20/18/15 NAS1638. 9		

◆ **HOW TO ORDER** 編號說明

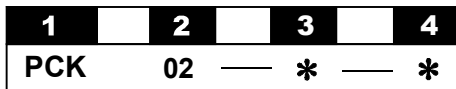

**1 VALVE SERIES** 系列名稱  
PCK = Pilot Operated Check Valves  
引導式止逆閥

**2 PORTING** 閥口  
02 : G1/4" 02AE : SAE4  
03 : G3/8" 03AE : SAE6  
04 : G1/2" 04AE : SAE8

**3 CHECK TYPE** 止逆型式  
Non : Standard 無記號:標準型  
A : Single Check 單邊止逆  
※Control port(s) please refer above.  
參考動作形式

**4 PILOT RATIO PILOT RATIO**  
4A : 4 : 1  
6A : 6 : 1

◆ **DIMENSIONS**

外型尺寸圖

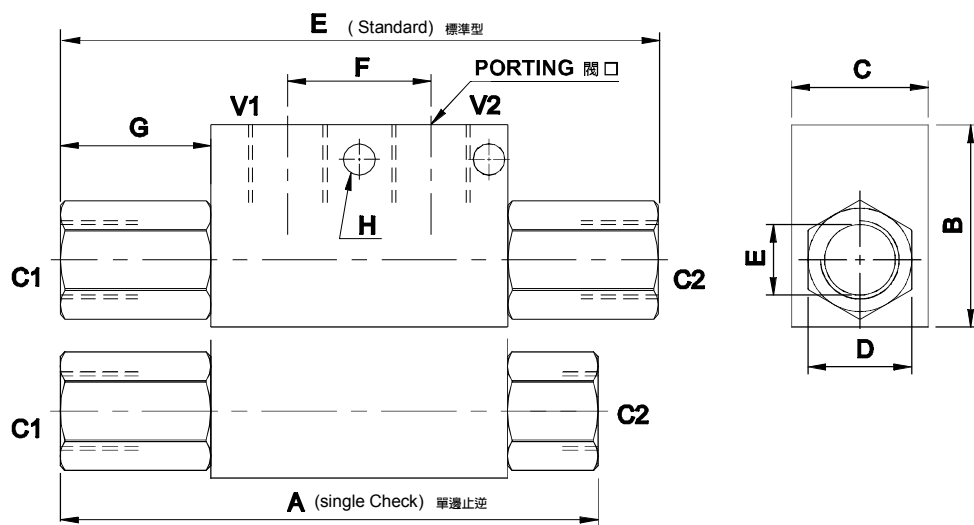

Size 尺寸 Model 型式	A	B	C	D	E	F	G	H
PCK-02	111 (4.37")	43 (1.69")	29 (1.18")	22 (0.87")	120 (4.72")	30 (1.18")	28 (1.10")	∅5.5 (0.21")
PCK-03	117 (4.60")	43 (1.69")	29 (1.14")	22 (0.87")	128 (5.04")	30 (1.18")	32 (1.26")	∅5.5 (0.21")
PCK-04	154 (6.06")	60 (2.36")	40 (1.57")	32 (1.26")	174 (6.85")	41 (1.61")	42 (1.65")	∅8.5 (0.33")