

◆ MODEL 型 式

DMS-04

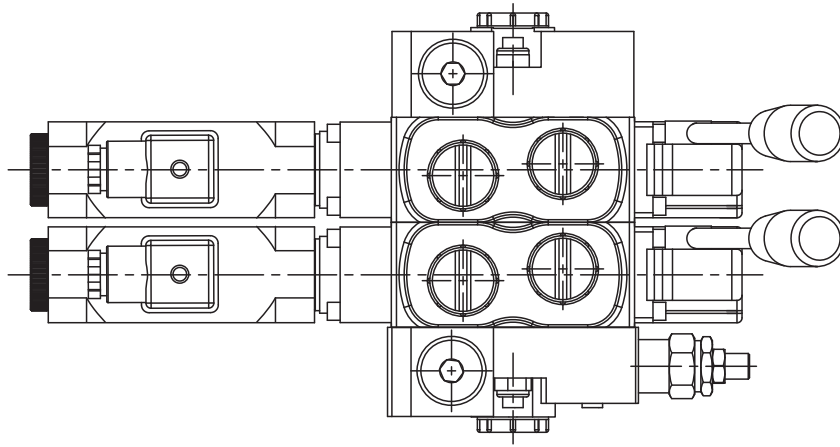

◆ CONTROL PORT(S) 動作形式

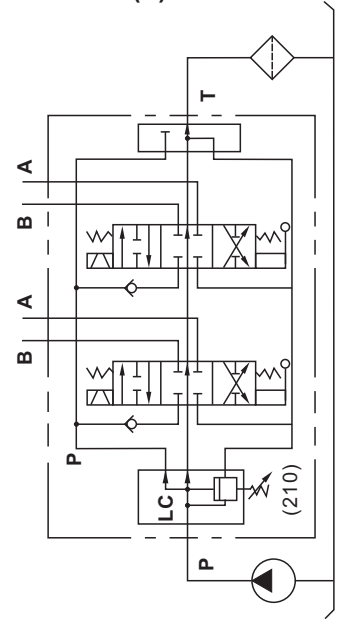

◆ SPECIFICATIONS 規 格

Model Number 型式號碼	Maximum Pressure 最大壓力 bar	Maximum Flow 最大流量 lpm	Weight 重量 Kg
DMS-03-**-**	350 (5075 psi)	45 (11.9gpm)	*
DMS-04-**-**	350 (5075 psi)	70 (18.5gpm)	*
Fluid Type 流體型式		ISO VG 32 , 46 , 68	
Viscosity 黏性 cSt		10~400 (59~1854 SSU)	
Operating Temperature 操作溫度 °C		-15~70 (-5~158 °F)	
Contamination Level 污染標準		$\beta_{10} \geq 75$, Under NAS Class 12, 25 μ	

● **Pressure regulation valve, Max. pressure 210 bar**
壓力調節閥標準最大壓力210bar

※Need to establish the pressure when 350bar, please tell in advance

※The relief valves please refer to the VRV-03 series

※如需設定壓力為350bar需先告知 ※調壓閥請參考VRV-03系列

◆ HOW TO ORDER 編號說明

1	2	3	4	5	6	7
DMS	04	C2	1N	I*	U*	**

1 VALVE SERIES 系列名稱

DMS = Solenoid Stack Valve (sectional)
電磁式多路換向閥(片式)

5 INLET SECTION 入油測

See Page 029
見頁面029

2 SUBPLATE MOUNTING SIZE 稱呼口徑

03 = G3/8" 04 = G1/2"

6 OUTLET SECTION 出油測

See Page 030
見頁面030

3 SPOOL TYPES 滑柱型式

See Page 028
見頁面028

7 COIL TYPES 電磁線圈類型

D1: DC12V D2: DC24V

4 NUMBER OF VALVE BLOCKS 連數

1N~7N = 1~7 BLOCKS

※The product needs the counter assembly please first to inform the factory, the counter assembly code number is "L"

※產品需逆組裝請先告知工廠，逆組裝代號為"L"。

STACK VALVE

DMS SERIES

多路換向閥系列

◆ DIMENSIONS 外型尺寸圖

● CARRY-OVER PLUG (on T1 Port)

轉接插頭 (接口在T1)

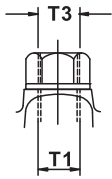

T1	T3	Purchasing No 訂貨編號
G 1/2"	G 1/2"	COG12
G 1/2"	G 1/2"	

※Extra attachment
※特別附件

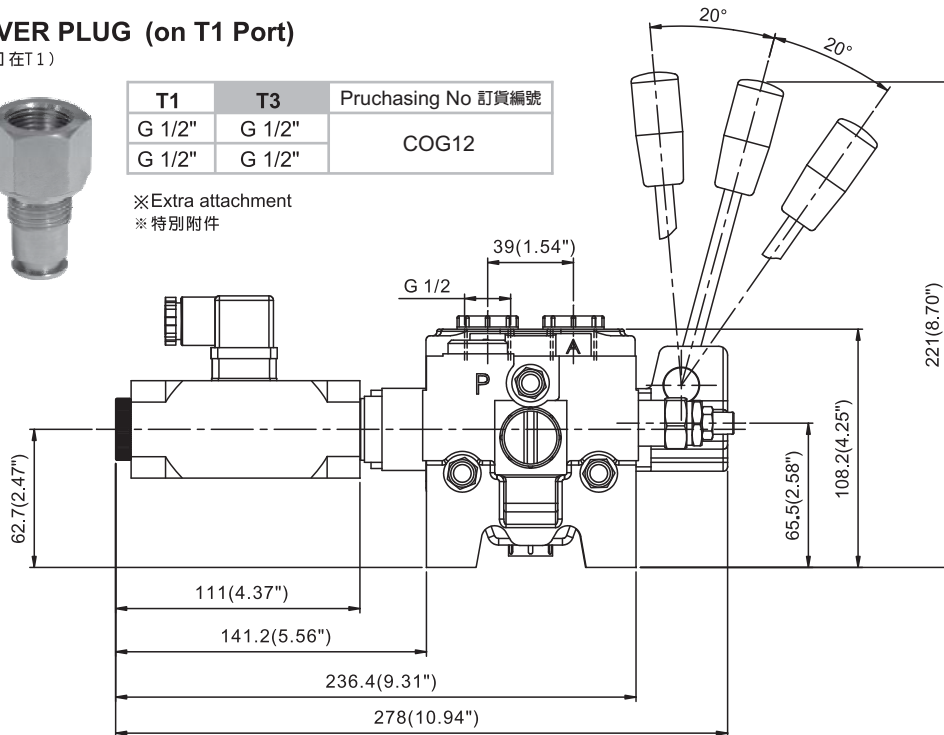

● CODE 編碼

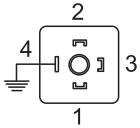

1-2 Port A
1-2 接口 A
1-3 Port B
1-3 接口 B

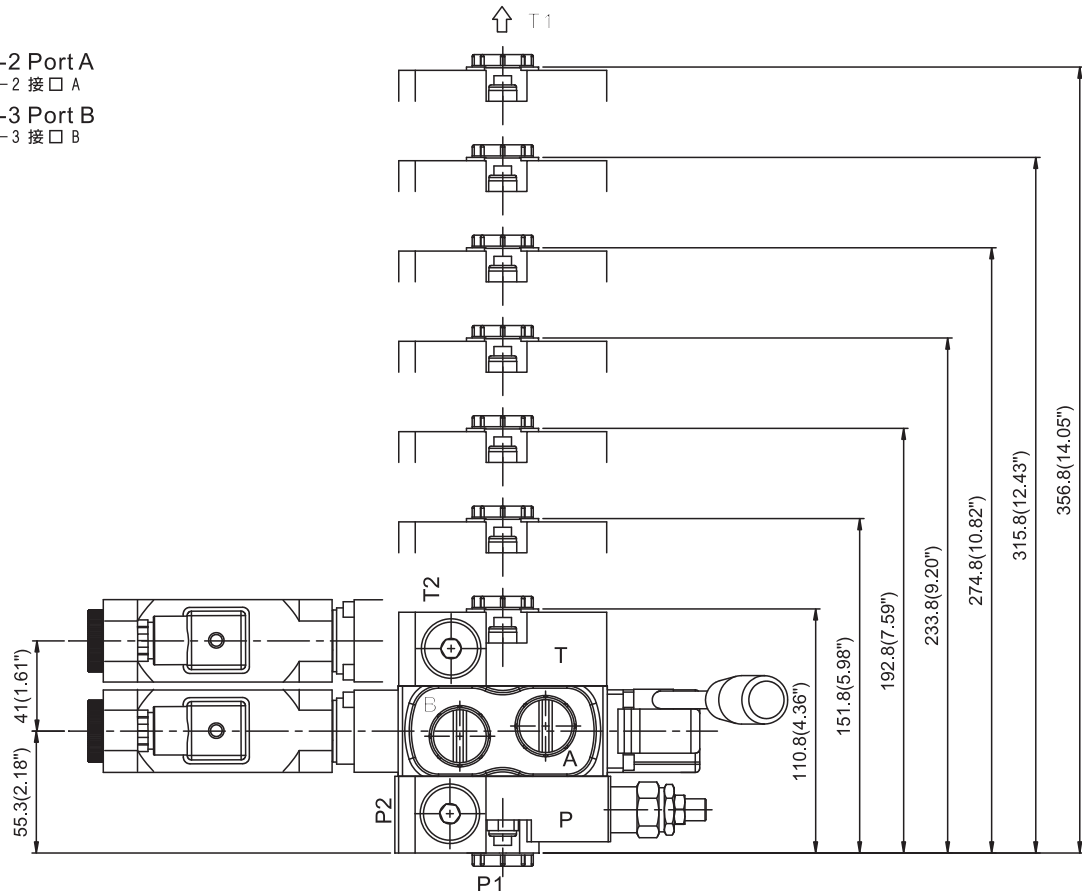

◆ AVAILABLE THREADS 適用螺紋

PORTS 閥口	P1	P2	A-B	T1	T2
DMS-03-**-**	G 1/2"	G 1/2"	G 3/8"	G 1/2"	G 1/2"
DMS-04-**-**	G 1/2"	G 1/2"	G 1/2"	G 1/2"	G 1/2"