

Solenoid Operated Two-way Check Valves

LVS SERIES

電磁雙向止逆閥

◆ MODEL 型 式

LVS-03T-1N

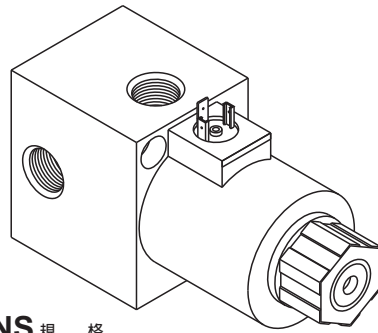

◆ CONTROL PORT(S) 動作形式

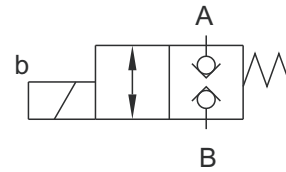

◆ SPECIFICATIONS 規 格

Model Number 型式號碼	Maximum Pressure 最大壓力 bar	Maximum Flow 最大流量 lpm	Weight 重量 Kg
LVS-03T-1N	210 (3046psi)	35 (8.81 gpm)	1.5 (3.3 lbs)
Fluid Type 流體型式	ISO VG 32 , 46 , 68		
Viscosity 黏性 cSt	10~400 (59~1854 SSU)		
Operating Temperature 操作溫度 °C	-15~70 (-5~158 °F)		
Contamination Level 污染標準	$\beta_{10} \geq 75$, Under NAS Class 12, 25 μ		
Surface Treatment 表面處理	Zinc Phosphate Compound 鋅磷酸鹽化合物		

● All of with Screens it's Cent meter Size and required Inch Size
所附螺絲皆為公制標準規格品，若需英制螺絲請另備註說明。

◆ HOW TO ORDER 編號說明

1	2	3	4	5
LVS	— 03	T	— 1N	— **

1 VALVE SERIES 系列名稱
LVS= SOLENOID OPERATED TWO-WAY CHECK VALVES
電磁雙向止逆閥

2 SUBPLATE MOUNTING SIZE: 稱呼口徑
03T= 3/8"(9mm)
ISO CETOP5
DIN NG 10
NFPA D05

3 CONNECTING TYPE 連接型式
T:TYPE: THREADING TYPE (螺紋連接)

4 NUMBER OF VALVE BLOCKS 連數
1N~5N=1~5 BLOCKS

5 TYPE OF COIL 電磁閥電磁線圈類型
A1 : AC110 60HZ D1: DC12
A115 : AC115 50HZ D2: DC24
A230 : AC230 50HZ R1: RF110 60HZ/50HZ
A2 : AC220 60HZ R2: RF220 60HZ/50HZ

◆ DIMENSIONS

外型尺寸圖

